

WINDOW TYPE CURRENT TRANSFORMER

6A412.3

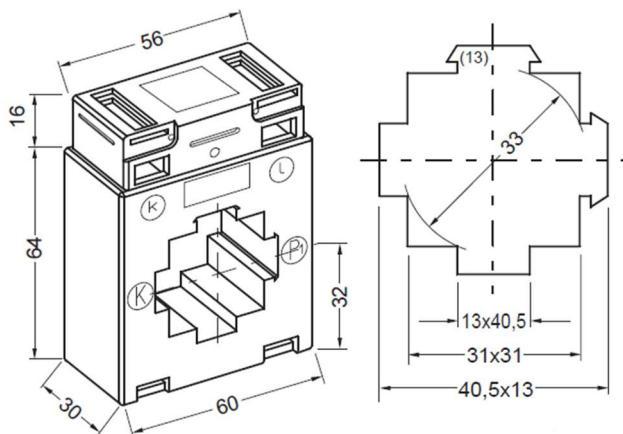

Round cable
Primary bus bar

Weight

33 mm
40 x 12 mm
2 x 30 x 10 mm
160 - 220 g

I_{sr}	Cl.	PRIMARY RATED CURRENT I_{pr}									A	
		150	200	250	300	400	500	600	750	800		
5 A	1		1,25	2	2,5	2,5	2,5	1,25	2,5	2,5	VA	
						3,75	5					
	0,5				2	2,5	2,5	2,5	1,25	2,5		2,5
							3,75	5				
1 A	1	2,5	2,5	2	2,5	2,5	2,5	2,5	2,5		VA	
			3,75			3,75	5					
	0,5		1,25	1,25	2,5	2,5	2,5	2,5	2,5			
						3,75	5					

ACCESSORIES (INCLUDED IN THE SCOPE OF SUPPLY):

1 pc.	Primary bus bar fixing device (Type 13),
2 pcs.	Threaded pin M5 x 35
2 pcs.	Secondary terminal cover (yellow sliders)
2 pcs.	Mounting feet

OPTIONAL ACCESSORIES

- Primary bus bar quick fastening device (Type 13-40)
- Snap-on mounting brackets for installation on DIN rail EN 50022-35
- Copper bus bars in different dimensions
- Insulating caps for the primary fixing threaded pins

GENERAL TECHNICAL DATA:

Highest voltage for equipment U_m	0,72 kV
Rated power frequency withstand voltage (r.m.s.)	3 kV / 1 min
Frequency	50 / 60 Hz
Rated continuous thermal current I_{cth}	$1,2 \times I_{pr}$
Instrument security factor	FS5 - FS15
Rated thermal current I_{th}	$60 \times I_{pr}$ for 1 s
Rated dynamic current I_{dyn}	$2,5 \times I_{th}$
Ambient temperature	-40 ... 40°C
Temperature rise limit class	H
Normative standards	IEC 61869 Part 1 + 2 DIN EN 42600
Enclosure	Break-proof polyamide Difficult to inflame
Secondary connection	Nickel plated cross-head screws (2 Nm) Integrated secondary terminal cover

SPECIAL DESIGNS (UPON REQUEST)

- Other ratings, burdens or accuracies
- Secondary reconnection
- Casted with resin
- Highest voltage for equipment 1,2 kV