

# BA386S steady state intrinsically safe LED beacon

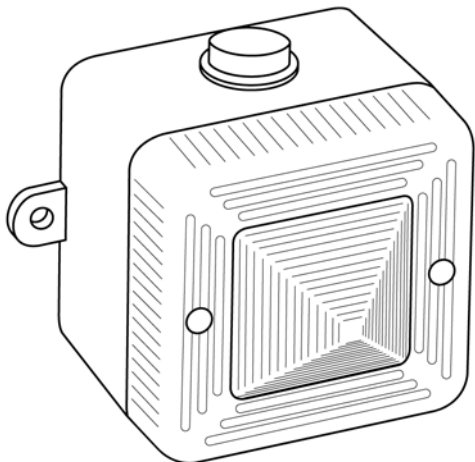

Issue 1 20th Nov 2018

The BA386S beacon is CE marked to show compliance with the European Explosive Atmospheres Directive 2014/34/EU and the European EMC Directive 2014/30/EU

## 1. INTRODUCTION

The BA386S is an ATEX, IECEx and FM certified intrinsically safe steady state beacon which produces a continuous visual output in a hazardous area. Five different colours are available. The beacon colour is shown on the external order code label and by the colour of the matching reflector behind the lens.

Order code	Colour
BA386SR	Red
BA386SA	Amber
BA386SG	Green
BA386SB	Blue
BA386SW	White

An intrinsically safe flashing beacon is also available. See BA386 datasheet. The BA386 flashing beacon can function alone, or in conjunction with a BEKA intrinsically safe sounder to form an audio and visual alarm system..

## 2. SUPPLY VOLTAGE

Fig 1 shows a simplified block diagram of a BA386S steady state beacon. The beacon will function immediately power is applied to terminals 1 and 2.

The BA386S beacon has been designed to operate in a hazardous area powered via a Zener barrier or galvanic isolator. The beacon may be tested or used in a safe area without a Zener barrier or galvanic isolator, but at supply voltages above 16V the internal current limit will function and the beacon brightness will be reduced. The beacon should not be continuously operated without a barrier or isolator with a supply voltage greater than 16V.

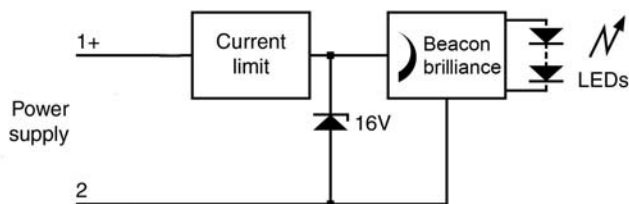

Fig 1 Simplified block diagram

## 3. INTRINSIC SAFETY CERTIFICATION

BA386S beacons have IECEx, ATEX and FM certification. IECEx and ATEX intrinsic safety certification is described in this section and FM intrinsic safety and nonincendive approval in Appendix 1.

### 3.1 ATEX and IECEx certification

Notified Body Intertek Testing and Certification Ltd have issued the BA386 beacon assembly with an IECEx Certificate of Conformity IECEx ITS 17.0052X and with an EU-Type Examination Certificate number ITS02ATEX2006X. The steady state BA386S beacon is electrically identical to the BA386 differing only in its operating firmware and order code.

The ATEX certificate confirms compliance with harmonised European standards and this has been used to confirm compliance with the European ATEX Directive for Group II, Category 1G equipment. The BA386S steady state beacon carries the community mark and, subject to local codes of practice, may be installed in any of the European Economic Area (EEA) member countries. ATEX certificates are also acceptable for installations in some non-EU countries such as Switzerland.

This instruction sheet describes IECEx and ATEX installations which conform with IEC/EN 60079-14 *Electrical installations design, selection and erection*. When designing systems the local code of practice should be consulted.

### 3.2 Zones, gas groups and T rating

The BA386S steady state beacon has been certified Ex ia op is IIC T4 Ga.  $-40^{\circ}\text{C} \leq T_a \leq 60^{\circ}\text{C}$ . When connected to a suitable system the BA386S may be installed in:

Zone 0	explosive gas air mixture continuously present.
Zone 1	explosive gas air mixture likely to occur in normal operation.
Zone 2	explosive gas air mixture not likely to occur, and if it does will only exist for a short time.

Be used with gases in groups:

Group A	propane
Group B	ethylene
Group C	hydrogen

In gases that may be used with equipment having a temperature classification of:

T1	450°C
T2	300°C
T3	200°C
T4	135°C

Although certified  $-40$  and  $+60^{\circ}\text{C}$ , the operating temperature of the beacon is  $-20$  to  $+60^{\circ}\text{C}$ .

### 3.3 Special conditions for safe use

The IECEx and ATEX certificates have an 'X' suffix indicating that special conditions apply, please see certificates.

#### CAUTION

When a BA386S beacon is installed in Zone 0, the installation shall be such that even in the event of rare incidents, an ignition source due to impact or friction between the aluminium label and iron/steel is excluded.

### 3.4 Certification label information

The certification label is fitted to the side of the beacon. It shows the model number, certification information and BEKA associates address. The year of manufacture is shown on an internal label. The beacon order code and the serial number are on a separate external label.



### 3.5 Terminals 1 & 2 - power supply

Power is supplied to the beacon via terminals 1 & 2 which have maximum input safety parameters of:

$$\begin{aligned} U_i &= 28V \\ I_i &= 110mA \text{ dc} \\ P_i &= 0.8W \end{aligned}$$

BA386S steady state beacons may be powered from any certified Zener barrier or galvanic isolator with output parameters equal to or less than these input parameters.

The equivalent internal capacitance and inductance  $C_i$  and  $L_i$  at terminal 1 & 2 of the beacon are both zero, the maximum permitted cable parameters are therefore the  $C_o$  and  $L_o$  specified by the certificate for the barrier or isolator powering the beacon.

## 4. INSTALLATION

In addition to the certification requirements shown in section 3 the environmental conditions must be within the limits shown on the product specification. The beacon enclosure provides IP66 protection and is suitable for installation in a sheltered exterior location if an appropriate sealed cable entry is used.

### CAUTION

Potential electrostatic charging hazard, do not rub beacon case or lens.

#### 4.1 Mounting

The BA386S beacon may be secured to any flat surface using the two 6mm diameter fixing holes. The lens should be aimed towards the area where maximum visibility is required.

#### 4.2 Installation procedure

- Remove the beacon lens assembly by unscrewing the two captive 'A' screws; carefully pull the assembly away from the back-box.
- Fit an IP66 M20 cable gland or conduit entry into one of the holes in the back-box and surface mount the back-box using the 6mm diameter holes in the two fixing lugs.
- Thread the field wiring through the cable gland or conduit entry in the back-box and connect the cable to the removable terminals on the lens assembly. Carefully replace the lens assembly and tighten the two 'A' screws.
- Beacon brilliance is adjustable using the control shown in Fig 3.

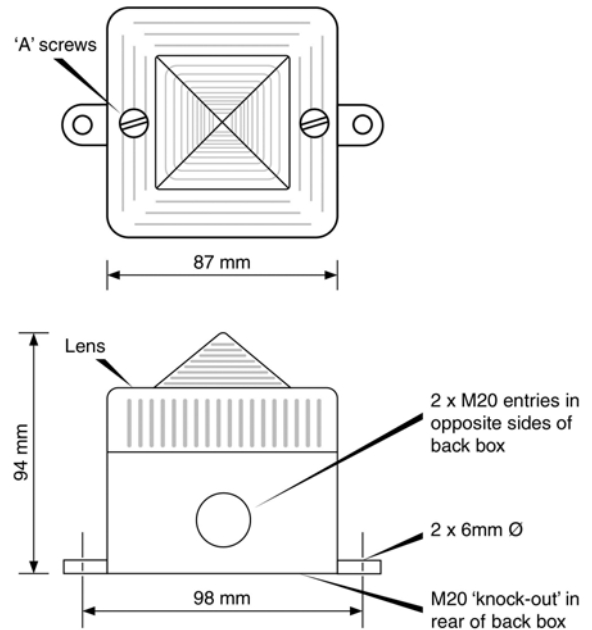

Fig 2 BA386S dimensions

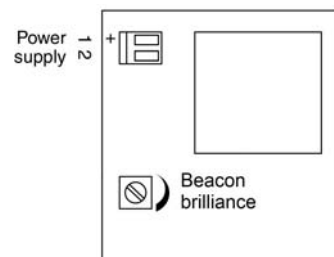

Fig 3 Location of field terminals and controls.

## 5. ELECTRICAL SYSTEM DESIGN FOR INSTALLATION IN HAZARDOUS AREAS USING ZENER BARRIERS

If the beacon is controlled by a switch in the positive supply, or the power supply is being turned *on* and *off*, only a single channel Zener barrier is required as shown in Fig 4. This circuit may also be used if the beacon is being controlled by a mechanically activated switch in the hazardous area. The power supply voltage should be between 20V and the maximum working voltage of the Zener barrier. The circuit will continue to work at lower voltages, but the beacon brilliance will be reduced.

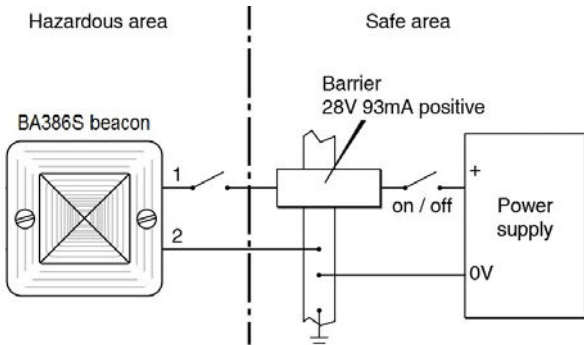

Fig 4 Using a single channel barrier

If the beacon control switch is in the negative wire and the power supply 0V is earthed, the circuit shown in Fig 5 may be used. For simplicity the two barriers may be combined into one package. The power supply voltage should be between 21V and the maximum working voltage of the 28V barrier. The circuit will continue to work at lower voltages, but the beacon brilliance will be reduced.

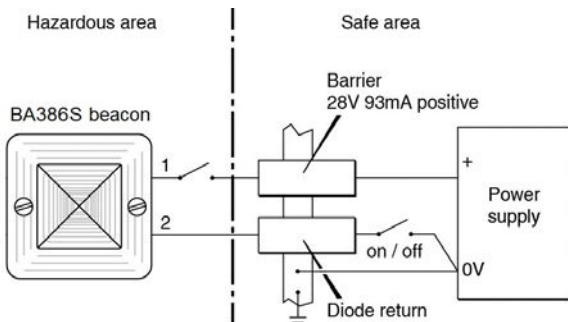

Fig 5 Single stage alarm using two channel barrier

### 5.1 Operating two beacons from one Zener barrier

Providing a small reduction in brilliance can be tolerated, two BA386S steady state beacons can be powered from one common Zener barrier. Each beacon can be independently controlled by a separate hazardous area switch, or from the safe area as shown in Fig 6

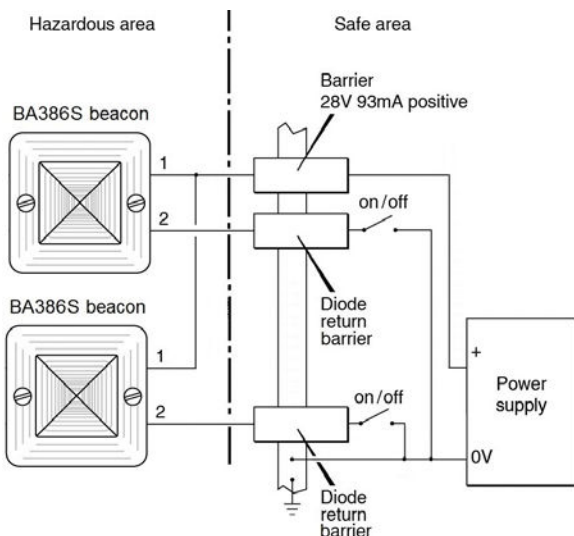

Fig 6 Powering two BA386S beacons from a one barrier

## 6. ELECTRICAL SYSTEM DESIGN FOR INSTALLATION IN HAZARDOUS AREAS USING GALVANIC ISOLATORS.

Although more expensive than Zener barriers, galvanic isolators are easier to install as they do not require a high integrity earth connection. Any certified device with output safety parameters equal to, or less than, the maximum input safety parameters of the BA386S beacon may be used – See section 3.5.

Fig 7 shows the basic circuit that is used for all applications. The control arrangement will vary depending upon the isolator chosen. The galvanic isolator must be able to supply an output of 25mA at about 16V. This circuit may also be used if the beacon is controlled by a mechanically activated switch on the hazardous area side of the isolator.

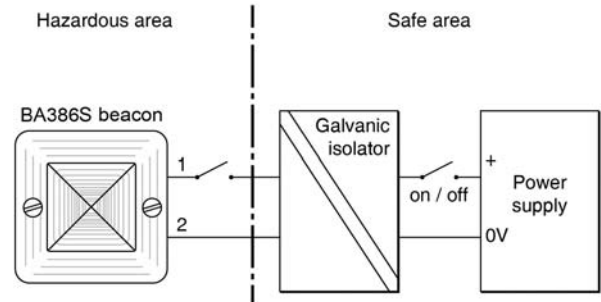

Fig 7 Basic circuit for use with a galvanic isolator.

Providing a small reduction in brilliance can be tolerated, two BA386S steady state beacons can be powered from one common galvanic isolator.

## 7. ACCESSORIES

### 7.1 Tag number

The BA386S beacon can be supplied identified by a tag number thermally printed on a self adhesive label.

## 8. MAINTENANCE

The beacon should be regularly inspected to ensure that it has not been damaged. Frequency of inspection depends upon environmental conditions.

**No attempt should be made to repair a faulty BA386S beacon. Suspect beacons should be returned to BEKA associates or your local BEKA agent for repair.**

## 9. GUARANTEE

Beacons which fail within the guarantee period should be returned to BEKA associates or your local BEKA agent. It is helpful if a brief description of the fault symptoms is provided.

## 10. CUSTOMER COMMENTS

BEKA associates are always pleased to receive comments from customers about our products and services. All communications are acknowledged and whenever possible, suggestions are implemented.

## APPENDIX 1 Installation in USA

### A1.1 Factory Mutual Approval

The BA386 beacon has the following Factory Mutual approval. The BA386S steady state beacon is identical to the BA386 differing only in its operating firmware and order code.

Intrinsic safety:

Class I Division 1 Gas groups A, B, C & D T4 Ta = 60°C

Class I Zone 0 AEx ia IIC T4 Ta = 60°C

Entity per BEKA Control drawing CI386-12

Nonincendive:

Class I Division 2 Gas groups A, B, C & D T4 Ta = 60°C

Class I Zone 2 IIC T4 Ta = 60°C

Nonincendive per BEKA Control drawing CI386-13

Intrinsically safe installations should comply with BEKA Control Drawing CI386-12 which is appended to the BA386 FM Certificate of Compliance on the BEKA website [www.beka.co.uk](http://www.beka.co.uk).

All the intrinsically safe circuits shown in this instruction sheet may be used for installations in the USA, providing the Zener barriers and galvanic isolators are Factory Mutual approved and comply with the specified entity parameters. Installations must also comply with the appropriate Control Drawing, ANSI/ISA RP12.6 and the National Electrical Code ANSI/NFPA70

### A1.2 intrinsic Safety Approval

The BA386 beacon has been evaluated under the entity concept. Terminals 1 & 2 of the beacon may be connected to any intrinsically safe circuit having output parameters equal to or less than:

$$\begin{aligned} \text{Voc, Vt} &= 32\text{V} \\ \text{Isc, It} &= 110\text{mA} \\ \text{Po} &= 0.8\text{W} \end{aligned}$$

The equivalent capacitance and inductance at terminals 1 & 2 are:

$$\begin{aligned} \text{Ci} &= 30\text{pF} \\ \text{Li} &= 0 \end{aligned}$$

Ci must therefore be subtracted from the maximum permissible cable capacitance specified for the Zener barrier or galvanic isolator powering the beacon.

The BA386S beacon has a T4 rating and may be used at ambient temperatures between -20 and +60°C.

**Note:** The BA386S beacon is not approved for use with Class II and III dusts and fibres.

### A1.3 Nonincendive Approval

The BA386S is also Factory Mutual approved nonincendive for Class I, Division 2 locations. This allows it to be installed in Division 2 without a Zener barrier or galvanic isolator when powered from a Factory Mutual approved associated apparatus having nonincendive output parameters equal to or less than:

$$\begin{aligned} \text{Voc} &= 32\text{V} \\ \text{Isct} &= 110\text{mA} \end{aligned}$$