



**Field Device Connectivity
for Digital Plant Asset
Management and Control**



Digital Plant Asset Management

The increasing scarcity of raw materials, the need for greater energy efficiency, and customer demand that is increasingly hard to predict require better performance and more flexibility in industrial production. In addition, the development of Industry 4.0 and the Industrial IoT create a rapidly changing environment for plant operation. Plant managers must find ways to improve productivity and cut operating costs while maintaining their workforce. To meet these challenges, digital plant asset management solutions are the way forward.

The essential precondition for the successful implementation of digital plant asset management and Industrial IoT is a seamless flow of information between production assets and software applications. Production facilities must be networked based on digital communication standards suitable for industrial applications. Secure and efficient device connectivity, the complete access to all data relevant to operation, commissioning, maintenance, and diagnostics provide the foundation for innovative industrial production.

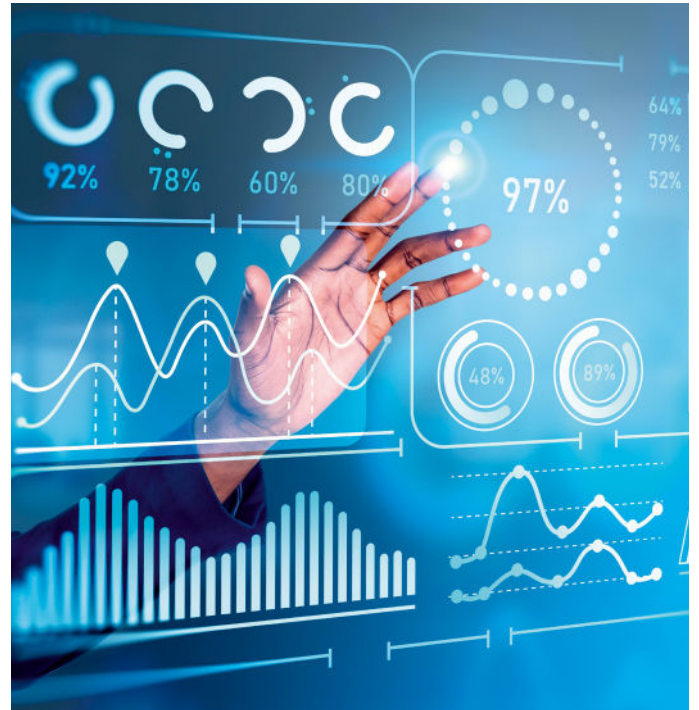

Ethernet Infrastructure



Industrial Ethernet protocols are the technological backbone of digital transformation: With Industrial Ethernet, automation networks are more efficient, more robust and more secure. At the same time, Industrial Ethernet makes automation networks easier to maintain. Using Industrial Ethernet for control helps to increase the level of automation and to simplify cabling. Also, Industrial Ethernet protocols are fast, allowing the transmission of large volumes of data. Recent technological progress, most notably the development of the Ethernet Advanced Physical Layer (Ethernet-APL) further increases the range of Industrial Ethernet applications in process industries. On top of this Ethernet infrastructure customers benefit from a complete technology stack consisting of PROFINET, PA profiles, PROFIsafe, and FDI.

Industrial-Grade Connectivity

Softing Industrial addresses the needs of the shopfloor with industrial grade connectivity products. Our products help plant operators to take full advantage of digital

plant asset management solutions, and to successfully deploy Industrial Ethernet protocols in their automation networks.

Asset Management



Access PROFINET Networks via FDI and OPC UA

The hardware gateway **smartLink HW-PN** and the Docker container software **smartLink SW-PN** enable controller-independent access to PROFINET field devices. In addition, access to PROFIBUS DP and PROFIBUS PA field devices connected via a PROFINET PROFIBUS proxy from Softing Industrial is possible. Supported are the Softing aplSwitch Field PA, Softing pnGate PA and Softing pnGate DP.

Integration can be carried out seamlessly and without affecting the ongoing operation of existing systems. Transparent PROFINET and PROFIBUS communication is ensured by the integrated FDI communication server, while an integrated 2-port switch in the hardware application enables use in Ethernet lines or ring structures. The application areas of smartLinks PN range from parameterization and asset management to the monitoring of PROFINET and PROFIBUS devices.

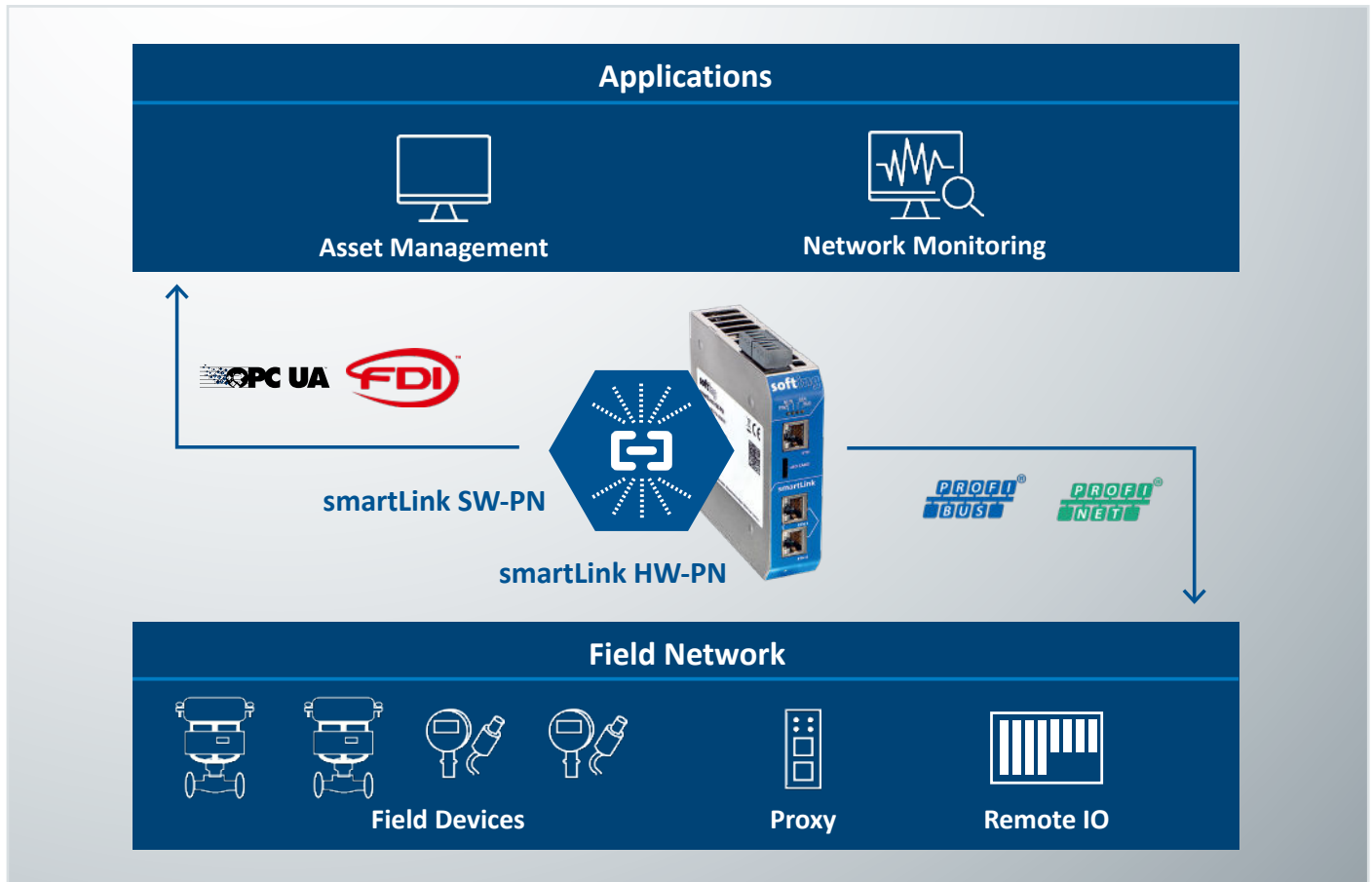

Parameterization, Plant Asset Management and Process Data Provision using Standard Industry Tools

- Independent of configuration tools
- Centralized and time-saving parameterization of PROFINET and PROFIBUS field devices directly from the control room
- Access from Plant Asset Management applications for field device configuration

Ethernet Access Point to PROFINET Networks

- Provides 2nd channel to access the field devices
- Acts as a PROFINET supervisor
- Hardware variant is part of one PROFINET network with integrated 2-port switch for use in line or ring network topologies
- Software variant supports multiple PROFINET networks and needs only standard Ethernet (UDP) connection to the PROFINET networks

Key Component for Transition to State-of-the-Art Technology

- Reuse of existing PROFINET networks without requiring modification
- Access to acyclic data via FDI communication server (OPC UA)



Connection of PROFIBUS and HART Devices to HART-IP, OPC UA, MQTT and FDT/DTM

smartLink HW-DP provides PLC independent access to PROFIBUS DP Networks. It enables plant asset management for field devices using standard industry tools and allows using HART-IP as a standardized format. smartLink HW-DP is a compact tool that can be integrated without interfering with the operation of existing installations. Thus, it enables Industry 4.0 connectivity for new and existing PROFIBUS DP networks.

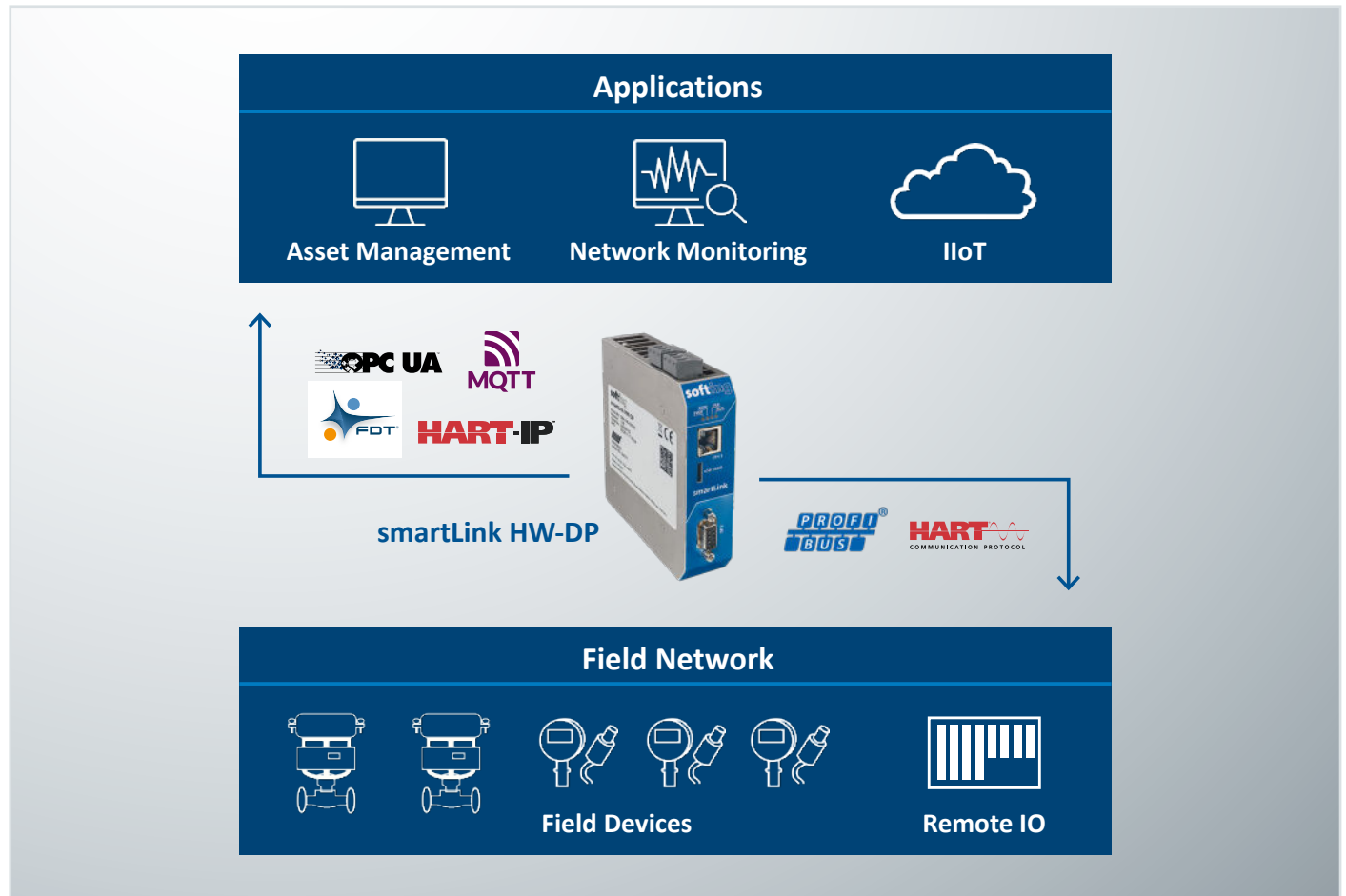

Configuration, Parameterization and Plant Asset Management Using Standard Industry Tools

- Independent of configuration tools
- Centralized and time-saving parameterization of PROFIBUS and HART field devices directly from the control room using HART IP and HART over PROFIBUS
- Access from Plant Asset Management applications for field devices configuration based on FDT/DTM and EDDL standards (acyclic master)

Ethernet Access Point to PROFIBUS DP

- Provides 2nd channel to access the field devices
- Acts as PROFIBUS DP master class 2
- Support of one PROFIBUS DP segment

Key Component for Transition to State-of-the-Art Technology

- Reuse of existing PROFIBUS segments without requiring modification
- Access to cyclic and acyclic data via HART-IP and OPC UA

Asset Management



Access to HART Devices from Emerson's AMS Device Manager and Other HART-IP Enabled Applications

smartLink SW-HT is a HART multiplexer that provides a simple and fast access to HART field devices without additional hardware. It is a software interface solution for HART devices connected to Allen-Bradley, Siemens, Schneider Electric, R.Stahl or Turck HART IO modules. The integrated HART-IP server enables transparent access to the HART devices. smartLink SW-HT enables remote asset management, device configuration and monitoring. It allows to access device identification, health, diagnostics, and process data.

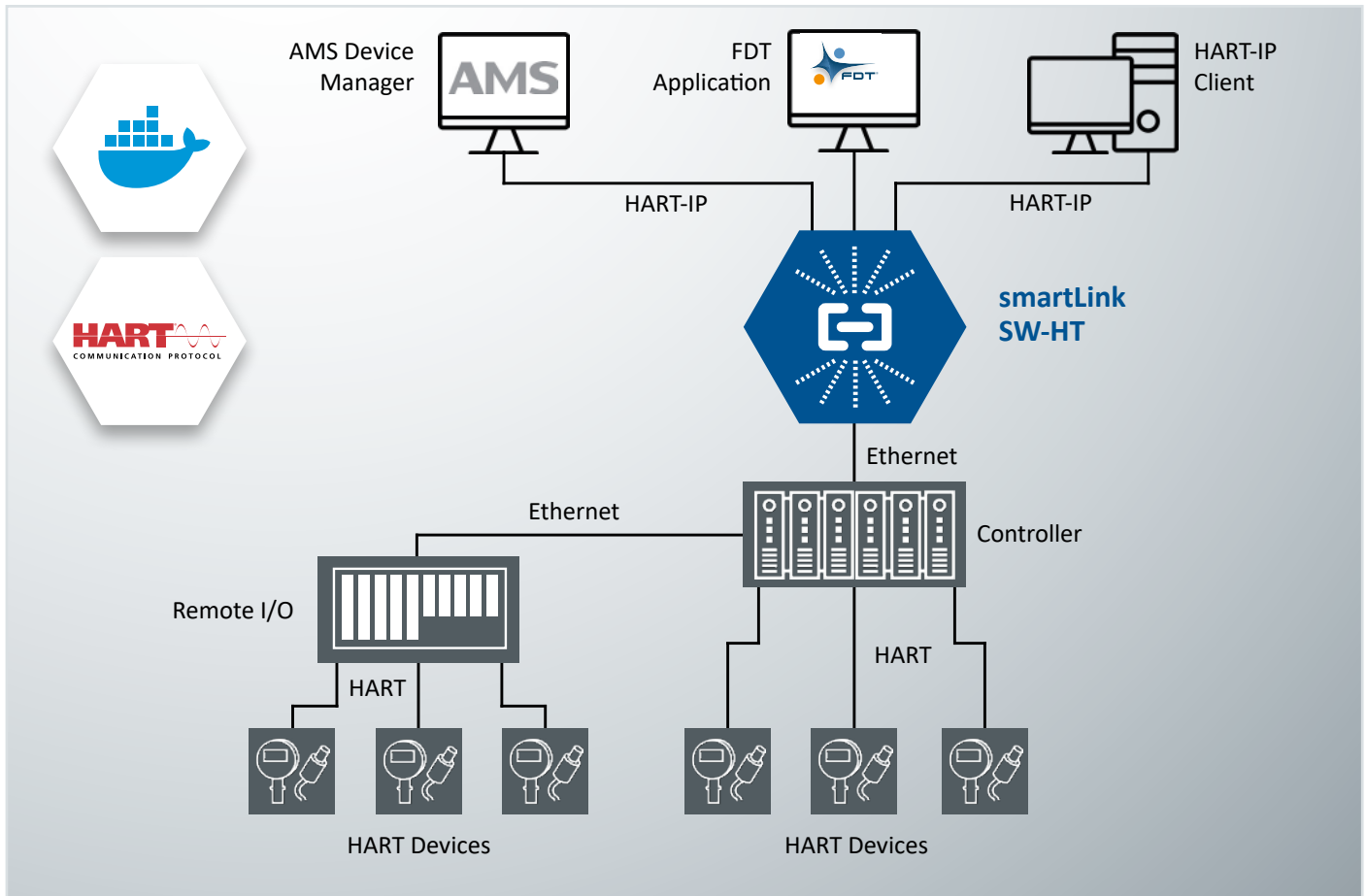

Access HART Devices without Additional Hardware

- Use the existing infrastructure to access the HART devices
- No additional cost for HART multiplexer hardware
- No installation and maintenance of additional Hardware
- Optional routing of the communication to the Allen-Bradley and Schneider Electric remote I/Os through the controller

Highly Scalable Business Model

- Pay only for the HART devices connected with smartLink SW-HT
- Scalable license model based on the number of HART devices to access
- Try it with 1 HART device for free

Transparent HART Communication

- The HART commands sent to the HART-IP server are forwarded to the HART devices
- No limitation on the supported HART commands
- Uses the open HART-IP protocol
- FDT Communication DTM for the integration into FDT applications

Easy Deployment

- Easy to use on a Windows workstation with the VM deliverable
- Supports Docker and Kubernetes for easy deployment by IT
- Web-based configuration software is included in the container



Health and Asset Monitoring of Industrial Communication Networks

plantPerfect Monitor provides full information about the health of the monitored industrial communication networks and all installed assets. With its support of smartLink HW-DP it supports monitoring of PROFIBUS networks.

Geared to plant operators and maintenance personnel, plantPerfect Monitor is a centralized, easy-to-use solution for permanent network health and asset monitoring. Based on state-of-the-art technology it meets the requirements of a modern and secure OT application.

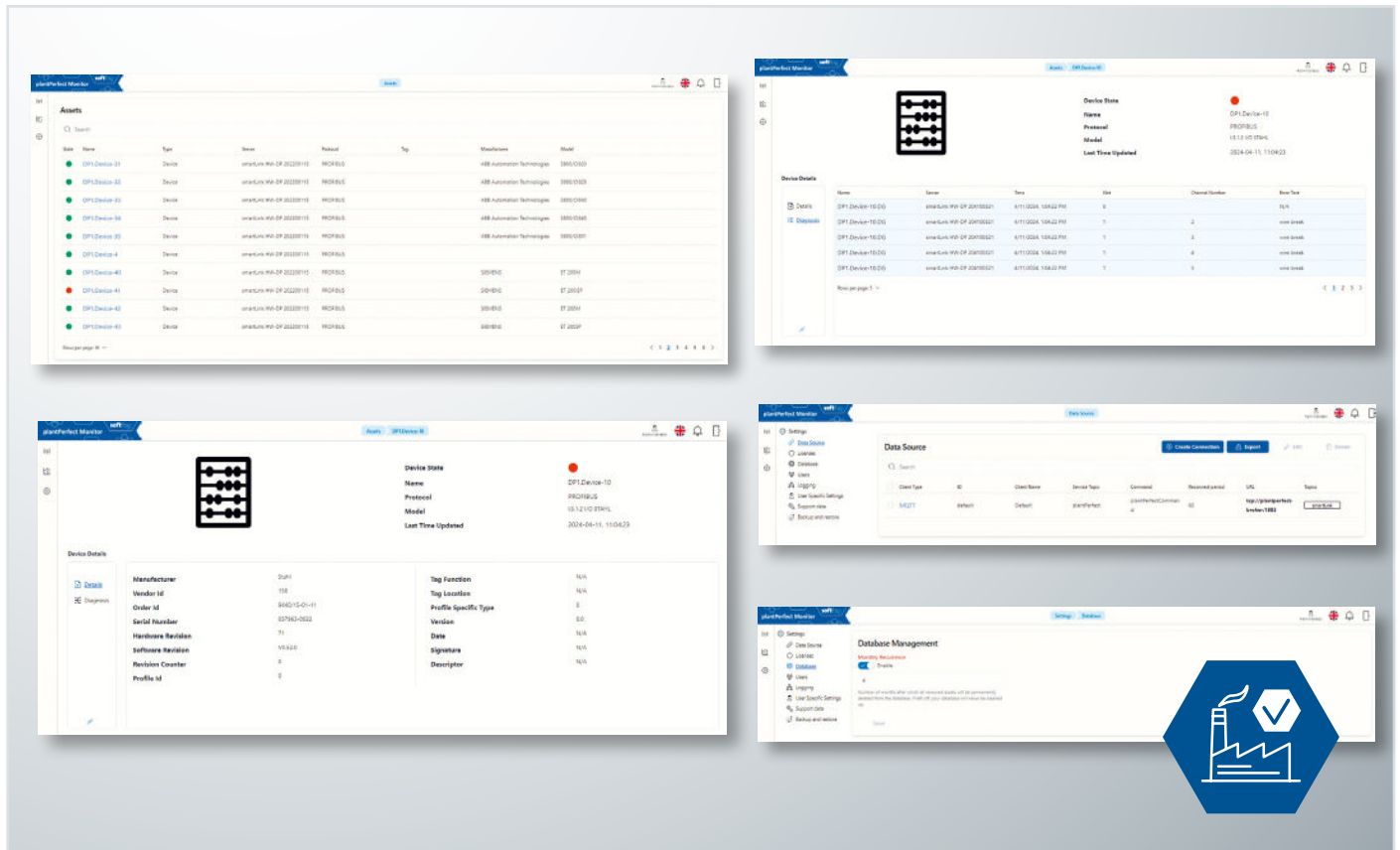

Centralized Monitoring Application

- Access to live and historical information
- Complete inventory data of all installed devices
- Trackability of diagnostic messages from the devices
- Support for PROFIBUS

Modern and Secure OT Application

- Web-based access
- Support for multiple organizations and users

Flexible and Scalable Business Model

- Choice between purchase and rental business model
- Scalable licensing based on the number of devices to be monitored

Easy Deployment

- Centralized maintainability through containerized architecture
- Easy to use on a Windows workstation with the VM deliverable



16 Port Ethernet-APL Field Switch with PA proxy for use in Zone 2

aplSwitch Field allows the transparent connection of intrinsically safe “2-WISE” Ethernet-APL field devices to higher-level Industrial Ethernet networks and supplies the field devices with intrinsically safe power.

aplSwitch Field PA allows the transparent connection of intrinsically safe “2-WISE” Ethernet-APL field devices as well as Profibus PA devices to higher-level Industrial Ethernet networks and supplies the field devices with intrinsically safe power.

Both switches can be installed in Zone 2 and can be integrated seamlessly into existing industrial automation systems.

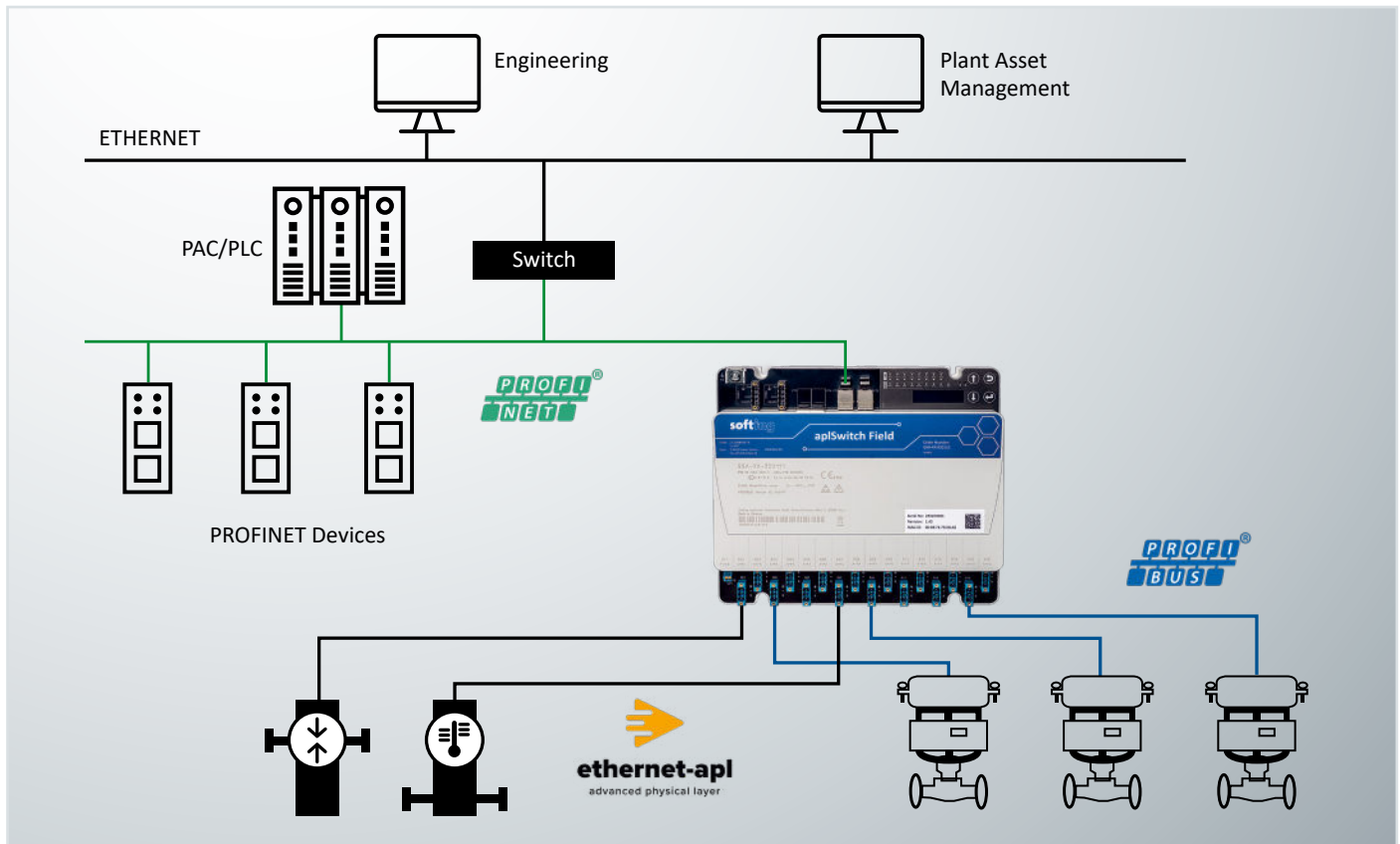

Ethernet-APL for Seamless and Reliable Integration into DCS and AMS Systems

- 16 Ethernet-APL spur „2-WISE“ ports
- PROFINET enabled switch with support for PROFINET MRP ring topology
- Support for all major DCS and AMS systems like Emerson, Siemens, ABB and others
- Ensuring stable networks via ingress/egress support

Extensive Diagnostics

- Integrated PROFINET diagnostic functions for easy commissioning, maintenance and troubleshooting
- Local display for instant commissioning diagnostics
- Enhanced FDI support for easy device integration and parameterization

Allows Installation in Hazardous Areas

- All product variants can be installed in Ex zone 2
- Field Devices located in Ex zone 0 and 1 can be connected
- Rugged and robust housing for field installation IP30

PowerClass A and B Support for APL Field Devices

- Allows usage of more complex/power-intensive field devices
- APL power class B supports up to 1,17 W per device on 4 ports
- Future-proof since no limitation to power class A with 0,54 W

Connects Ethernet-APL and PROFIBUS PA Devices

- Easy migration of the existing PA infrastructure to the APL topology
- Support for Ethernet-APL or PROFIBUS PA devices or a mixture of these devices on one switch
- PROFIBUS PA devices over integrated PROFINET proxy



Integration of FOUNDATION Fieldbus H1 Segments Into Control Systems via Modbus TCP or FOUNDATION Fieldbus HSE

FG-200 allows integration of up to four FOUNDATION Fieldbus (FF) H1 links into control systems that support Modbus. The FG-200 provides redundancy and is suitable for use in hazardous areas. The device provides fast access to process data while making use of FF advantages like reduced cabling, central field device parameterization, comprehensive diagnostics, or intrinsically safe device segments. It is compatible with the R. STAHL bus-Carrier Series 9419 and Fieldbus Power Supply Series 9412 products for easy commissioning.

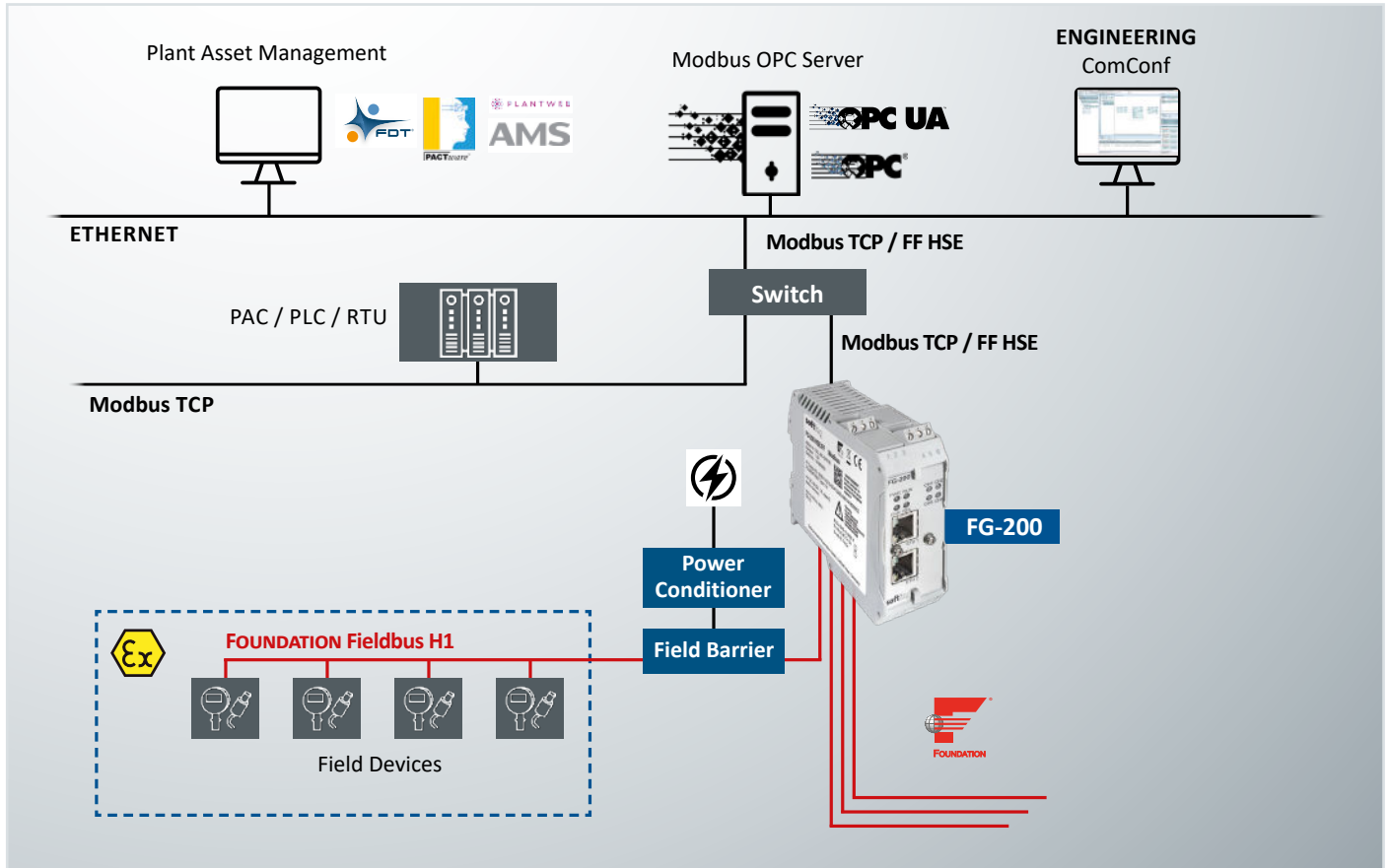

CAPEX-efficient Integration of FF-Devices into Modbus Architectures

- Parallel support of up to 4 FF-H1 channels, each for max. 16 field devices
- Fast access to process data
- Suitable for use in hazardous areas
- Easy Commissioning:
 - Optional support of R. STAHL bus-Carrier Series 9419 and Fieldbus Power Supply 9412 products (cabling reduced to a minimum)
 - Modbus data import to web server reducing mapping efforts

Device Redundancy

- Redundancy link enabling device redundancy (D-3 according to FF-593)
- Automatic mirroring of configuration data
- Very fast redundancy switchover

Suited for Plant Asset Management Tasks

- Visitor mode for avoiding interference with network behavior
- Enabling asset management systems e.g. Emerson's AMS and Field Device Tool (FDT) frame applications e.g. SMART VISION, FieldMate, Field Device Manager, FieldCare, or PACTware

All Necessary Tools Included

- FF Configuration Tool for configuration of devices and cyclic communication
- PACTware for device configuration and basic asset management tasks



Direct Integration of PROFIBUS DP and PA Segments into PROFINET Control Systems

pnGate PB / pnGate PA / pnGate DP allow the integration of up to four PROFIBUS PA segments and one PROFIBUS DP segment into PROFINET systems by virtual mapping. The pnGates reduce the engineering costs since they reuse existing power conditioners in technology upgrade projects. They provide S2 redundancy and enable configuration, parameterization and plant asset management using standard industry tools.

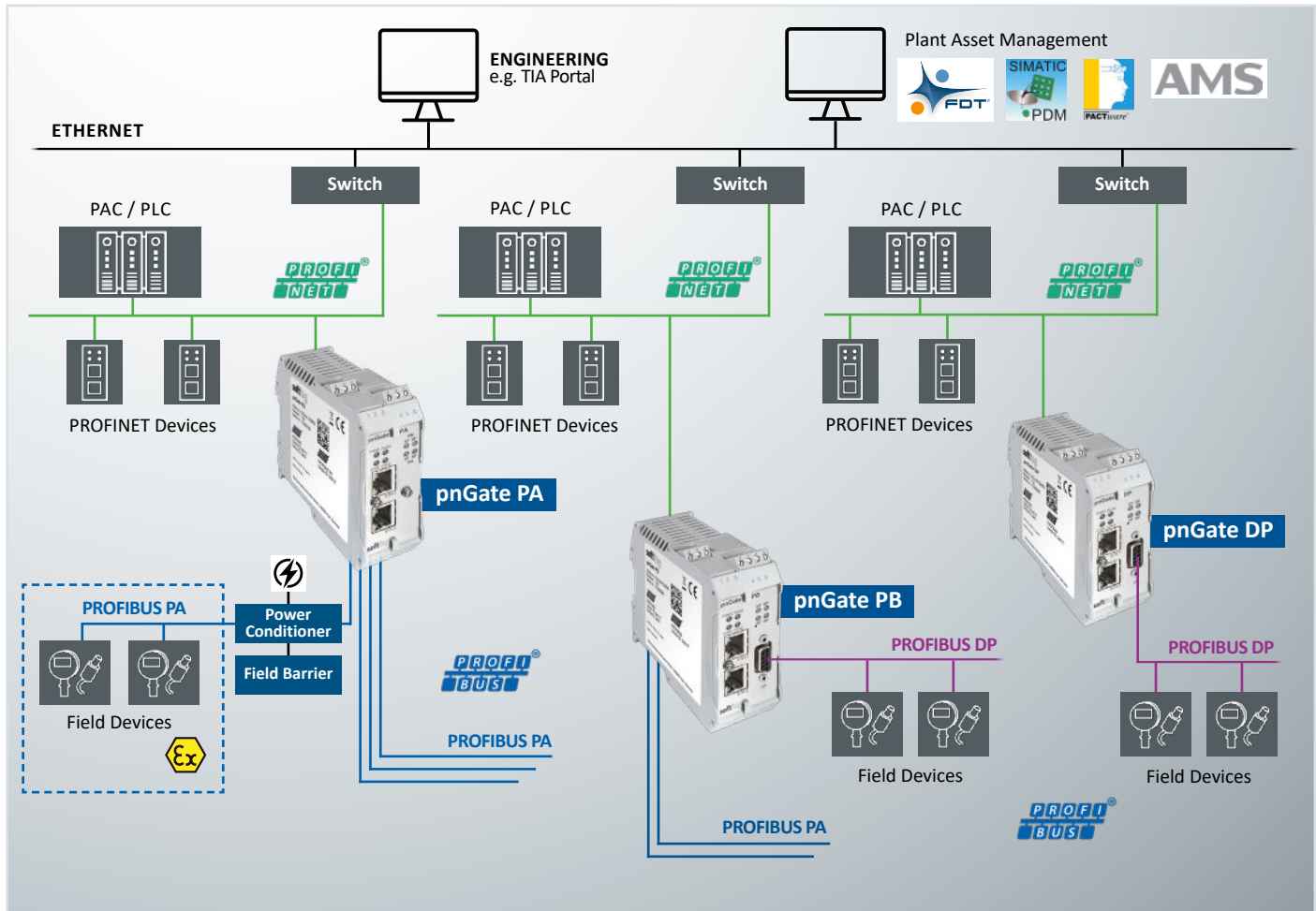

Key Component for Transition to State-of-the-Art Technology

- Simple replacement of installed PROFIBUS DP/PA segment coupler
- Reuse of existing PROFIBUS segments without requiring modification
- Support of MRP and S2 PROFINET redundancy for increased reliability

Direct Connectivity to PROFIBUS Segments

- Single access point to PROFIBUS DP and PROFIBUS PA segments from PROFINET networks
- Acting as PROFINET device, PROFIBUS PA and PROFIBUS DP Master
- Support of 1 PROFIBUS DP segment and up to 4 PROFIBUS PA segments
- Support of up to 64 PROFIBUS devices

Configuration, Parameterization and Plant Asset Management Using Standard Industry Tools

- Support of major PROFINET engineering tools such as TIA Portal, Step7 and PC WORX
- Included CommdTM allows use in FDT/DTM frame applications
- EDD-based device parameterization using Siemens Simatic PDM
- Maximum flexibility through Configuration in Run support



Simple Connection of PROFIBUS Slave Devices to Modbus Control Systems via Internal I/O Mapping

mbGate PB / mbGate PA / mbGate DP enable integration of up to four PROFIBUS PA segments and one PROFIBUS DP segment into Modbus TCP control systems. They act as Modbus TCP Server and PROFIBUS Master. The gateways help reduce engineering costs since they re-use existing power conditioners in technology upgrade projects. They enable configuration, parameterization and plant asset management using standard industry tools.

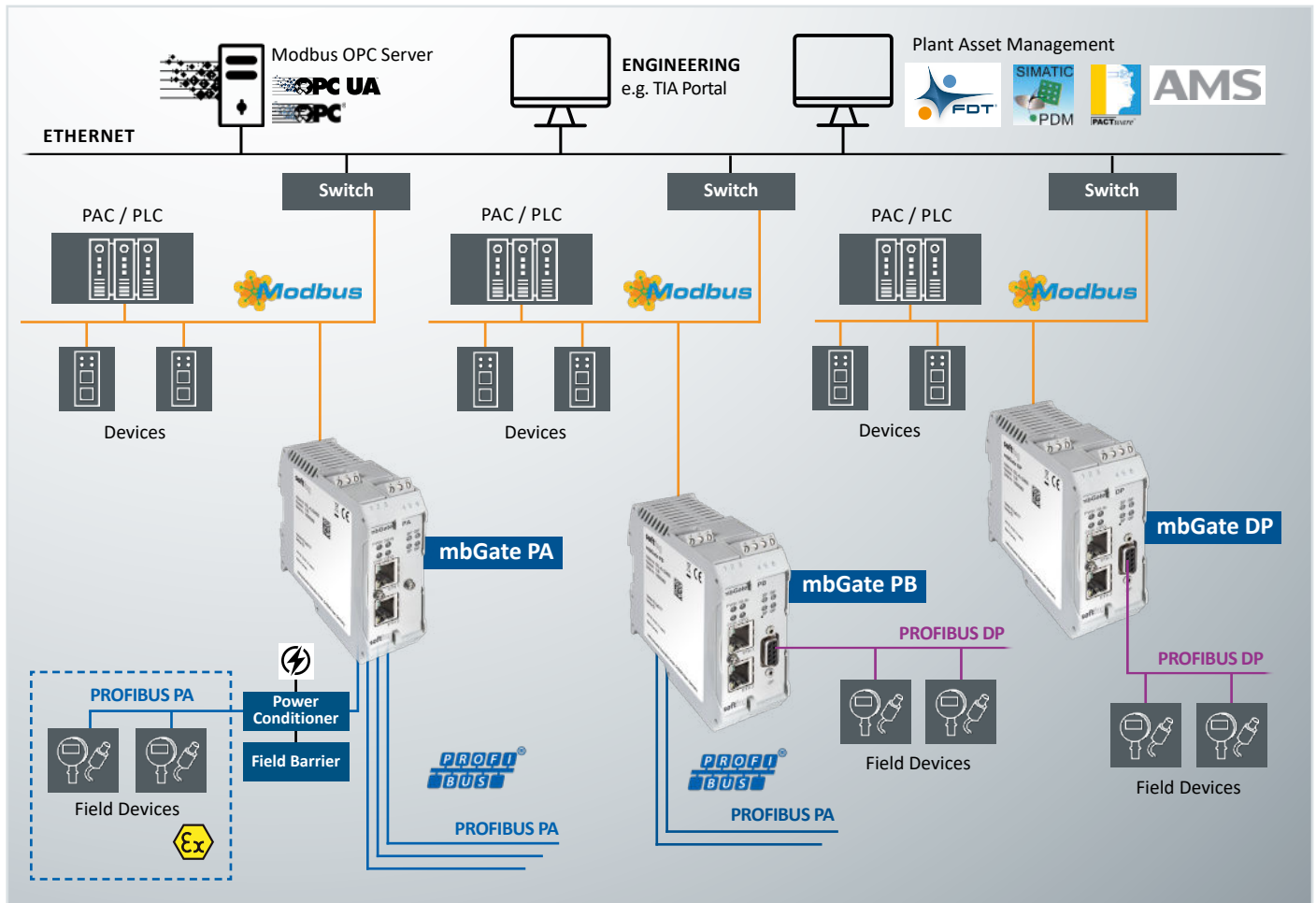

Key Component for Transition to State-of-the-Art Technology

- Simple replacement of installed PROFIBUS DP/PA segment couplers
- Re-use of existing PROFIBUS segments without requiring modification

Direct Connectivity to PROFIBUS Segments

- Single access point to PROFIBUS DP and PROFIBUS PA segments from Modbus TCP networks
- Acting as Modbus TCP Server and PROFIBUS PA and PROFIBUS DP Master
- Support of 1 PROFIBUS DP segment and up to 4 PROFIBUS PA segments
- Support of up to 64 PROFIBUS devices

Configuration, Parameterization and Plant Asset Management Using Standard Industry Tools

- Support of major Modbus engineering tools such as Schneider Unity Pro or Siemens TIA Portal
- Included CommdTM allows use in FDT/DTM frame applications
- EDD-based device parameterization using Siemens Simatic PDM

MODBUS/TCP Redundancy

- Support for the use of two redundant PLCs and two redundant gateways
- Easy activation via licensing
- Full control of redundant operation mode via engineering and PLC



Direct Integration of PROFINET I/O Devices or PROFIBUS Slave Devices into EtherNet/IP Control Systems via Internal I/O Mapping

epGate PN implements a gateway between an EtherNet/IP scanner (e.g. a Rockwell PLC) and up to 32 PROFINET devices. While the gateway's upper RJ45 socket connects to the EtherNet/IP network as a so-called adapter (slave), the gateway acts as a PROFINET controller (master) through its lower RJ45 socket. This allows for integration of PROFINET devices and subsystems into EtherNet/IP applications.

epGate PB / epGate PA / epGate DP enable integration of up to four PROFIBUS PA segments and one PROFIBUS DP segment into EtherNet/IP systems. The gateways help reduce engineering costs since they reuse existing power conditioners in technology upgrade projects. They enable configuration, parameterization and plant asset management using standard industry tools.

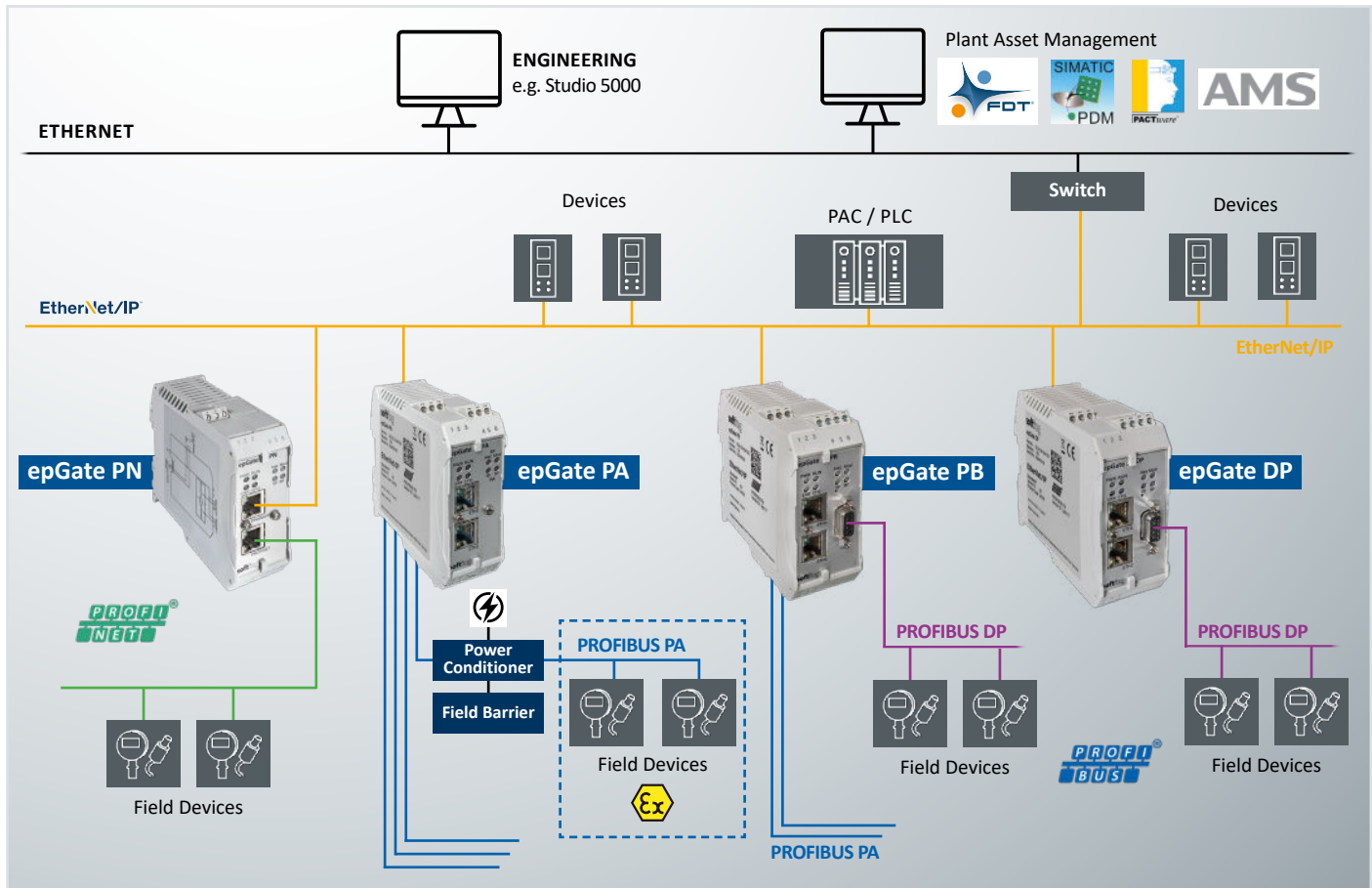

epGate PN – EtherNet/IP to PROFINET Gateway with Controller Functionality

- Connection to the EtherNet/IP network via the so-called adapter (slave); (upper RJ45 socket)
- PROFINET controller (master) functionality (lower RJ45 socket)
- Direct access from EtherNet/IP scanner in the PLC to PROFINET field devices
- Data access of PLC program to PROFINET devices without requiring detailed PROFINET knowledge
- Mapping between the two protocols generated by provided tools

epGate DP/PA/PB – EtherNet/IP to PROFIBUS DP/PA Master Gateway

- Support of common control systems e.g. Emerson DeltaV or Rockwell ControlLogix
- Support of DLR for redundant communication in the ring with EtherNet/IP
- Single access point to PROFIBUS DP and PROFIBUS PA segments from EtherNet/IP networks
- Acting as EtherNet/IP device (adapter), PROFIBUS PA and PROFIBUS DP master
- Support of major EtherNet/IP engineering tools such as Studio 5000 and AMS Device Manager
- Data access of PLC program to PROFIBUS devices possible without extensive PROFIBUS knowledge



Bluetooth and USB Solution for Commissioning, Parameterization, and Maintenance of Field Devices

mobiLink is a mobile USB and Bluetooth interface. The Bluetooth and battery operation enables use with handheld host devices such as tablets and smartphones. **mobiLink** can be used in a variety of applications since it is compatible with FDT Frame applications and other major engineering tools. Additionally, it is suited for harsh environments (approved by IECEx and EX for Zone 1). **mobiLink Power** enables a direct connection to the field device without it having to be located within a functioning bus infrastructure. The integrated power supply eliminates the need for additional components such as external power supply and terminating resistors for commissioning and maintenance of the field devices.

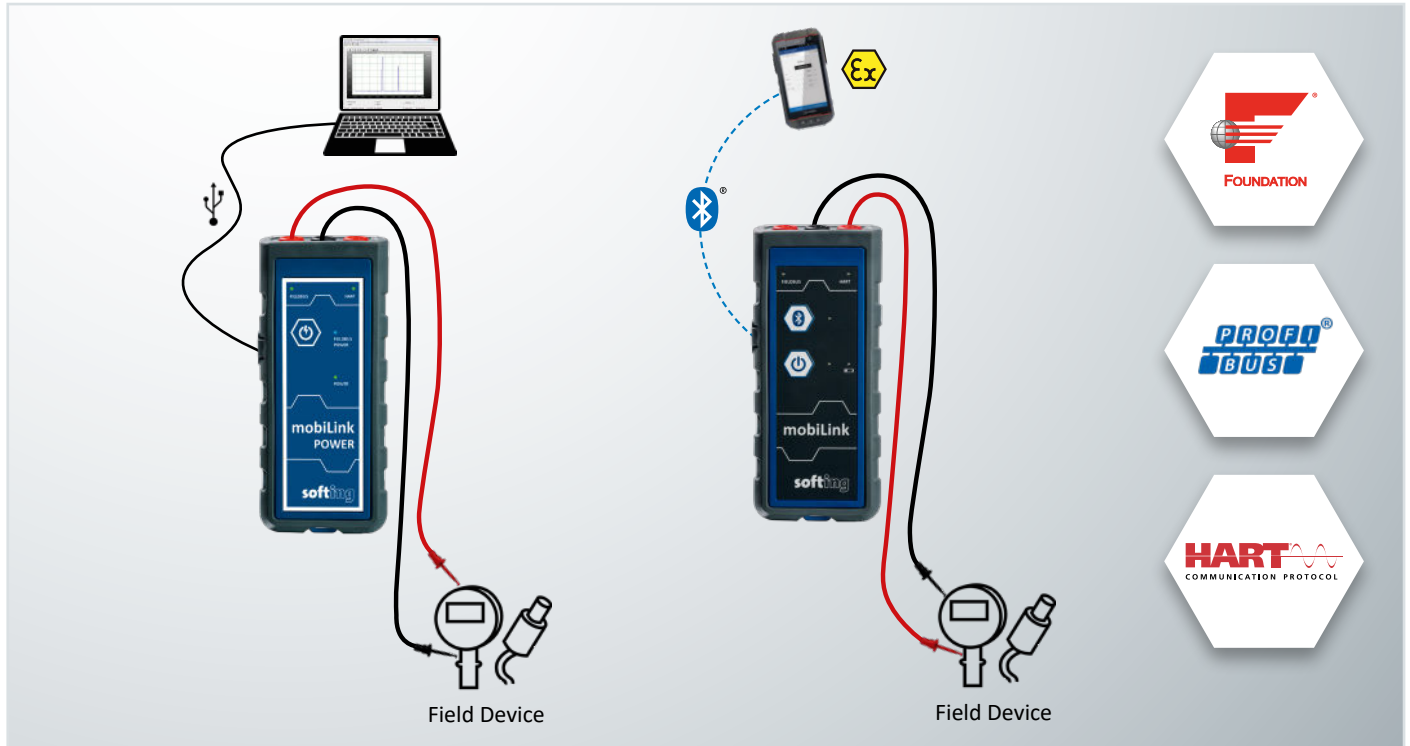

Single Interface for the Major Process Automation Protocols

- HART master, FOUNDATION Fieldbus host and PROFIBUS PA master included in one device

Support of FDT Frame Applications and Major Engineering Tools

- Compatible with Emerson's instrument inspector with the FDI communication server
- PACTware FDT frame application and HART communication DTM included
- Communication DTM for FOUNDATION Fieldbus and PROFIBUS PA (optional)
- FOUNDATION Fieldbus configuration tool (optional)
- Application Programming Interface for integration into engineering

Host communication via Bluetooth or USB

- Built-in batteries and Bluetooth communication enable use of handheld host devices like smart phones and tablets
- USB interface for bench host operation

mobiLink – Bluetooth and USB interface

- Temporary attachment to fieldbus segments or HART loops for individual interaction with field devices
- Fully compliant protocol implementations allow for interference-free access to running plants
- IECEx and EX approval for Zone 1, NEC500 Cl. Div.1
- Suitable for connection to intrinsically safe circuits
- Suited for harsh environment

mobiLink Power – USB interface

- Provision of power supply for field devices
- Eliminates the need for an additional power supply and power conditioner for workbench applications
- Power supply via the USB port of the connected computer



Namur Open Architecture (NOA)

Access to Process Data in PLCs, Field Device Connectivity, and OPC UA Server Aggregation Compliant with NOA

The automation pyramid simplifies process automation, but accessing field data (i.e. from field devices, machines, PLCs, etc.) for IoT and Industry 4.0 applications this way is difficult. For leveraging the OPC UA interoperability standard, Namur Open Architecture (NOA) offers a secure second channel to access sensor and PLC data, and to send it to monitoring and optimization applications without changes to an existing automation network and its configuration.

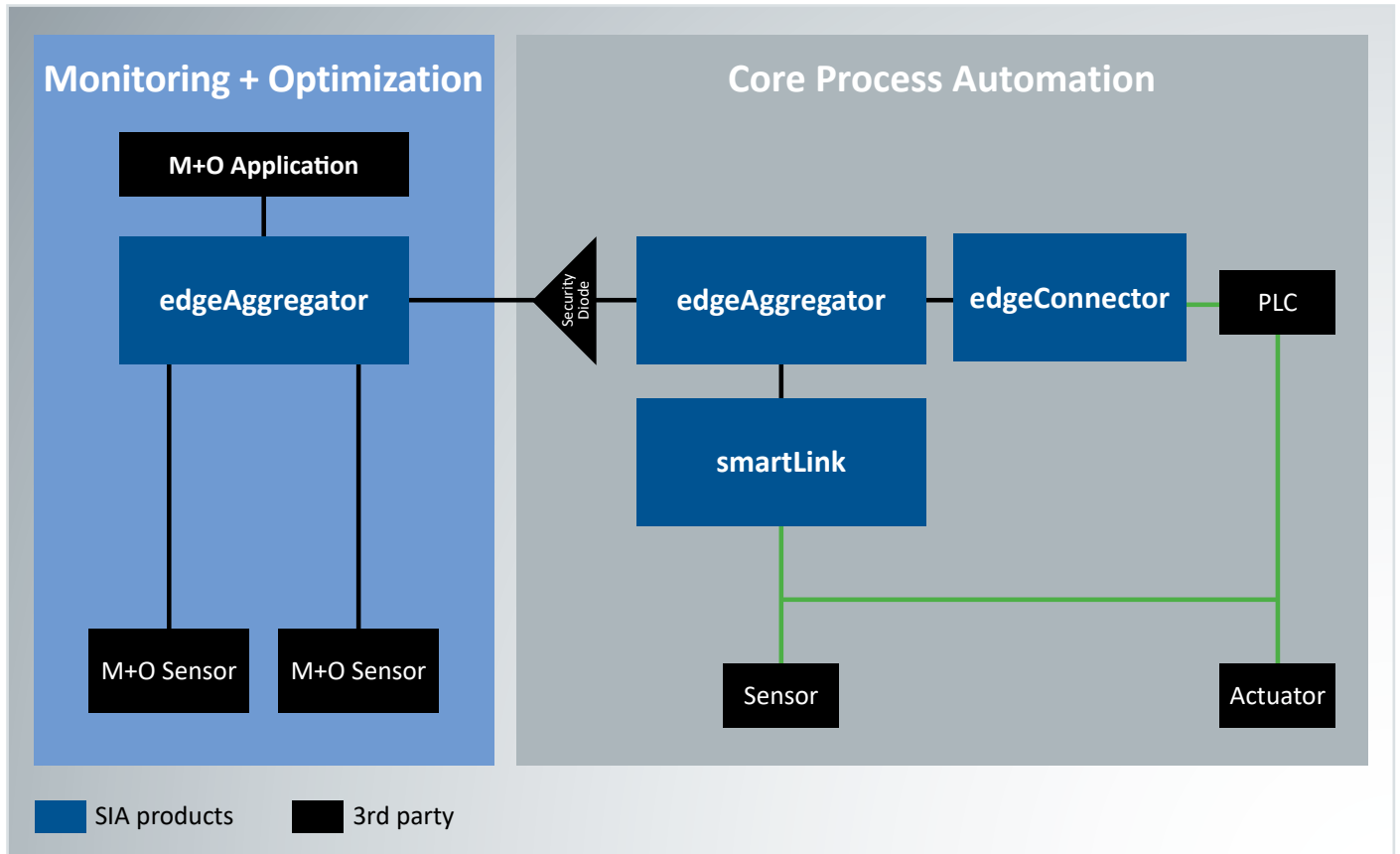

Softing Industrial offers a range of connectivity products which comply with the NOA reference architecture as outlined in the diagram above. The products provide access to machine- and process data in PLCs, as well as PLC independent access to field device data. They also support OPC UA server aggregation which can be applied on multiple levels in a complete solution, further simplifying the implementation of a second communication channel.

smartLink Product Family

- smartLink products provide access to field device data (sensors, actuators) for IIoT, asset management, and network monitoring applications.

edgeConnector Product Family

- edgeConnector products provide access to process and machine data in PLCs for M&O and other IIoT applications (e.g OEE, predictive maintenance, machine learning, etc.)

edgeAggregator

- The edgeAggregator provides OPC UA server aggregation and additional IT security features.



Softing Expertise

Digital data exchange based on industrial communication standards is a core competence of Softing. From an early stage, we focused our attention on technologies relevant to process automation and ex-capable hardware. Softing experts contributed substantially to the specification of e.g., PROFIBUS and Foundation Fieldbus. To this day, Softing is actively involved in the technical workgroups of the FieldComm Group, PROFIBUS & PROFINET International, ODVA and the OPC Foundation.

The innovation potential of Industrial IoT solutions has broadened our range of activities. Among other projects, we were involved in the definition of the Namur Open Architecture (NOA) standard.

Based on this technological know-how, we offer innovative and reliable connectivity products for digital plant asset management and Industrial IoT solutions and act as a strategic partner for plant operators and system integrators.

